

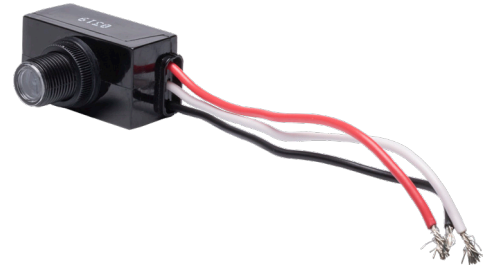

CONTRACTOR	
PROJECT	DATE
PREPARED BY	MODEL :

SERIES SPECIFICATIONS

PHOTO ELECTRIC SWITCH MULTI-VOLT WALL MOUNT



CONSTRUCTION

Sensor

IR-Filtered Phototransistor

Sensitivity

time delay 5 seconds

Source

Natural Light

Supply Voltage

120-277AVC

Power Consumption

0.4W max

Ambient Light

16Lx On; 24Lx Off

Frequency Rating

50/60Hz

Size

54.5*29*44mm

Operating Cycles

5000

Output

500W Tungsten, 850VA Bal-last; 4A@120VAC/2.5A@208~277V e-Bal-last

Enclosure

Lock nut*1pc; flat neoprene Gasket*1pc; Rain tight lens protection cover*1pc

LED Rating

300W

CERTIFICATIONS/WARRANTY

Listing

UL773 Listed

Warranty

Guaranteed for one year from the purchase date of the product, against mechanical defects in manufacturing.

ORDERING INFORMATION

Part Number: PES-MV-WM

APPLICATION AND PERFORMANCE SPECIFICATION INFORMATION IS SUBJECT TO CHANGE WITHOUT NOTIFICATION



11675 SW TOM MACKIE BLVD. DR. PORT ST. LUCIE, FL 34987 | 772.408.5213 | WWW.RPP-USA.COM



CONTRACTOR	
PROJECT	DATE
PREPARED BY	MODEL :

WIRING DIAGRAM

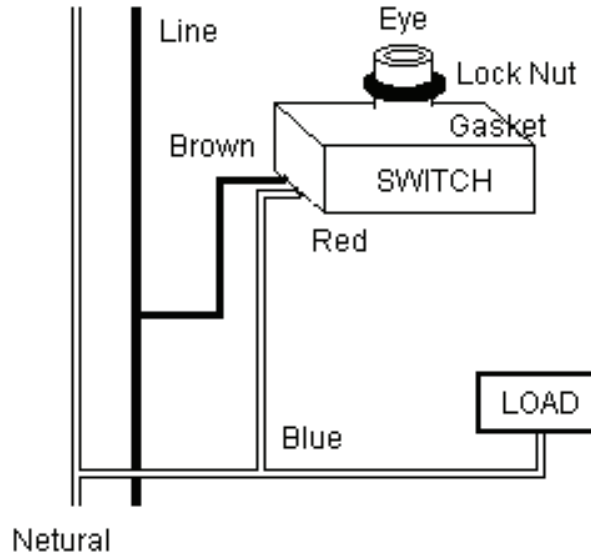

APPLICATION AND PERFORMANCE SPECIFICATION INFORMATION IS SUBJECT TO CHANGE WITHOUT NOTIFICATION

